

prior to publication. We also thank Professor Gary Schnuelle for his helpful comments. P.A.K. also acknowledges the useful comments of Professor N. Ostlund, who described his applications of counterpoise corrections and dipolar scaling; these were of great help to this study.

References and Notes

- (1) P. Kollman and I. D. Kuntz, *J. Am. Chem. Soc.*, **96**, 4766 (1974).
- (2) See, for example, P. Kollman, "Modern Theoretical Chemistry: Ab Initio Methods", H. F. Schaefer, Ed., Plenum Press, New York, N.Y., 1976.
- (3) J. Almlöf, A. Kvik, and J. O. Thomas, *J. Chem. Phys.*, **59**, 3901 (1973).
- (4) J. Bacon and D. P. Santry, *J. Chem. Phys.*, **56**, 2011 (1972).
- (5) C. Ghio, E. Scrocco, and J. Tomasi, "Environmental Effects on Molecular Structure and Properties", B. Pullman, Ed., D. Reidel, Dordrecht, Holland, 1976.
- (6) H. Kistenmacher, H. Popkie, and E. Clementi, *J. Chem. Phys.*, **59**, 5842 (1973).
- (7) A. Pullman and B. Pullman, *Q. Rev. Biophys.*, **7**, 505 (1975).
- (8) D. L. Beveridge, M. M. Kelley, and R. J. Radna, *J. Am. Chem. Soc.*, **96**, 3769 (1974).
- (9) J. Hylton, R. E. Christofferson, and G. G. Hall, *Chem. Phys. Lett.*, **24**, 501 (1974).
- (10) M. Newton, *J. Chem. Phys.*, **58**, 5833 (1973); *J. Phys. Chem.*, **79**, 2795 (1975).
- (11) J. O. Noell and K. Morokuma, *Chem. Phys. Lett.*, **36**, 465 (1975); see S. Yamabe, S. Kato, H. Fujimoto, and K. Fukui, *Theor. Chim. Acta*, **30**, 327 (1973), for an approach similar to this using a point dipole approximation.
- (12) P. Kollman and I. D. Kuntz, *J. Am. Chem. Soc.*, **94**, 9236 (1972).
- (13) P. Kollman, unpublished results.
- (14) H. Veillard, J. Demuynck, and A. Veillard, *Chem. Phys. Lett.*, **33**, 221 (1975).
- (15) P. Kollman, M. McKelvey, A. Johansson, and S. Rothenberg, *J. Am. Chem. Soc.*, **97**, 955 (1975).
- (16) E. Clementi and J. N. Gayles, *J. Chem. Phys.*, **47**, 3837 (1967).
- (17) (a) NH_3HCl : B. Ault and G. C. Pimentel, *J. Phys. Chem.*, **77**, 1649 (1973).
(b) H_2OHCl : *ibid.*, **77**, 57 (1973).
- (18) P. Kollman and L. C. Allen, *J. Am. Chem. Soc.*, **93**, 4991 (1971).
- (19) R. Ditchfield, M. D. Newton, W. H. Hehre, and J. A. Pople, *J. Chem. Phys.*, **54**, 724 (1971).
- (20) Dr. D. M. Hayes and P.A.K. would like to acknowledge the aid of W. J. Hehre in expanding the capabilities of the GAUSSIAN 70 version on the Lawrence Berkeley Lab CDC 7600.
- (21) H. Kistenmacher, H. Popkie, and E. Clementi, *J. Chem. Phys.*, **58**, 5627 (1973).
- (22) I. Dzidic and P. Kebarle, *J. Phys. Chem.*, **74**, 1466 (1970).
- (23) T. Dunning, *J. Chem. Phys.*, **58**, 2833 (1970).
- (24) E. Clementi and H. Popkie, *J. Chem. Phys.*, **57**, 1077 (1972).
- (25) J. J. Delpuech, G. Serratrice, A. Strich, and A. Veillard, *Mol. Phys.*, **29**, 849 (1975).
- (26) P. Kebarle, "Environmental Effects on Molecular Structure and Properties", B. Pullman, Ed., D. Reidel, Dordrecht, Holland, 1976.
- (27) M. Arshadi, R. Yamdagni, and P. Kebarle, *J. Phys. Chem.*, **74**, 1475 (1970).
- (28) A. Johansson, P. Kollman, and S. Rothenberg, *Theor. Chim. Acta*, **29**, 167 (1973).
- (29) The electric field due to the point charge goes as $1/r^2$ rather than $1/r^3$ for a dipole. For the total stabilization of the ion pair, we must multiply the result of evaluating eq 2 by 2.
- (30) F. D. Rossini, "Selected Values of Chemical Thermodynamic Properties", NBS-500 (1973). The value of HF (aq) was not given, but was estimated by assuming the reaction enthalpy for $\text{HF}(\text{g}) \rightarrow \text{HF}(\text{aq})$ was the same as that for $\text{NH}_3(\text{g}) \rightarrow \text{NH}_3(\text{aq})$ ($\Delta H = -8.28$ kcal/mol). This leads to an enthalpy for the reaction $\text{NH}_3(\text{aq}) + \text{HF}(\text{aq}) \rightarrow \text{F}^-(\text{aq}) + \text{NH}_4^+(\text{aq})$ of -18.6 kcal/mol. A reasonable estimate for the uncertainty of the $\text{HF}(\text{g}) \rightarrow \text{HF}(\text{aq})$ reaction is ± 2 kcal/mol so we can conclude that the ionic structures are favored over nonionic by -18.6 ± 2 kcal/mol.
- (31) For example, using our previously calculated H-bond energies for NH_3 and HF with each other and with water, we estimate the energy for the reaction $\text{H}_3\text{N}\cdots\text{HF}(\text{neutral, aq}) \rightarrow \text{NH}_3(\text{aq}) + \text{HF}(\text{aq})$ to be -6.0 kcal/mol. This leads one to expect a calculated difference between neutral and ionic ($\text{NH}_3\cdots\text{HF}$) of -24.6 kcal/mol, if it is to be quantitatively consistent with the experimental enthalpies. Our best "extrapolated" value as the number of H_2O approaches ∞ is -15 to -20 kcal/mol.
- (32) M. Newton and S. Ehrenson, *J. Am. Chem. Soc.*, **93**, 4971 (1971).
- (33) D. Demoulin and L. C. Allen, submitted for publication.

Solvated Electron Reaction Rates in Alcohols and Water. Solvent Effect¹

Gerald L. Bolton and Gordon R. Freeman*

Contribution from the Chemistry Department, University of Alberta, Edmonton, Alberta, Canada T6G 2G2. Received February 9, 1976

Abstract: In alcohols electron capture by sulfur hexafluoride is less efficient than that by oxygen. This is the reverse of the relative efficiencies in the gas phase. Solvation affects the electron attachment efficiency by altering the energetics of the reaction. The ratio of electron capture rate constants for a given solute in methanol and ethanol, $k_{4,M}/k_{4,E}$, decreases with decreasing reactivity of the solute. The ratio varies from a maximum ≥ 2.0 for diffusion controlled reactions, with $k_{4,M} \geq 6 \times 10^{10} \text{ M}^{-1} \text{ s}^{-1}$, to a minimum of 0.18 for $k_{4,M} \leq 10^7 \text{ M}^{-1} \text{ s}^{-1}$. The upper limit of the ratio is due to the higher diffusion coefficients in methanol. The decrease is due to the greater solvation energy of electrons in methanol, which makes electron transfer from the solvent trap to the less efficient solutes more endoergic in methanol than in ethanol. At 296 K the ratio of rate constants for neutral scavengers in the two alcohols is given by $(k_{4,M}/k_{4,E}) = \exp([1.6 - 0.38\Delta G_{4,M}^\ddagger]/0.59)$ when $\Delta G_{4,M}^\ddagger < 6.8$ kcal mol^{-1} , and by $(k_{4,M}/k_{4,E}) = 0.18$ when $\Delta G_{4,M}^\ddagger > 6.8$ kcal mol^{-1} , where $\Delta G_{4,M}^\ddagger$ is the free energy of activation of reaction of a given solute with solvated electrons in methanol. The free energies of activation in methanol and ethanol are related by the equations: $\Delta G_{4,E}^\ddagger = (0.62\Delta G_{4,M}^\ddagger + 1.6)$ when $\Delta G_{4,M}^\ddagger < 6.8$ kcal mol^{-1} , and $\Delta G_{4,E}^\ddagger = (\Delta G_{4,M}^\ddagger - 1.0)$ when $\Delta G_{4,M}^\ddagger > 6.8$ kcal mol^{-1} .

Introduction

This article has two purposes, (a) to report values of rate constants for reactions of solvated electrons with dissolved gases, including common impurities and popular additives, and (b) to describe a solvent effect on electron reaction rates.

Nitrous oxide and sulfur hexafluoride are the most commonly used electron scavengers in alcohol radiolysis, yet the rate constants of their reaction with solvated electrons have not been measured.^{2,3} Carbon dioxide is difficult to remove completely from liquids and is an efficient electron scavenger

in water⁴ and hydrocarbons,⁵ but its rate constant has not been measured in alcohols. Oxygen is a common impurity whose rate constant for reaction with solvated electrons has been measured in water⁴ and alcohols;⁶ the rate constants have been remeasured for comparison. Acetylenes and conjugated olefins react with sodium-potassium alloy; electrons from the alloy react with acidic protons on acetylenes⁷ to form hydrogen and a salt, while electrons simply add to conjugated olefins (hydrogen is not evolved). It was therefore interesting to measure and compare the rate constants of solvated electron reactions with these two types of compound.

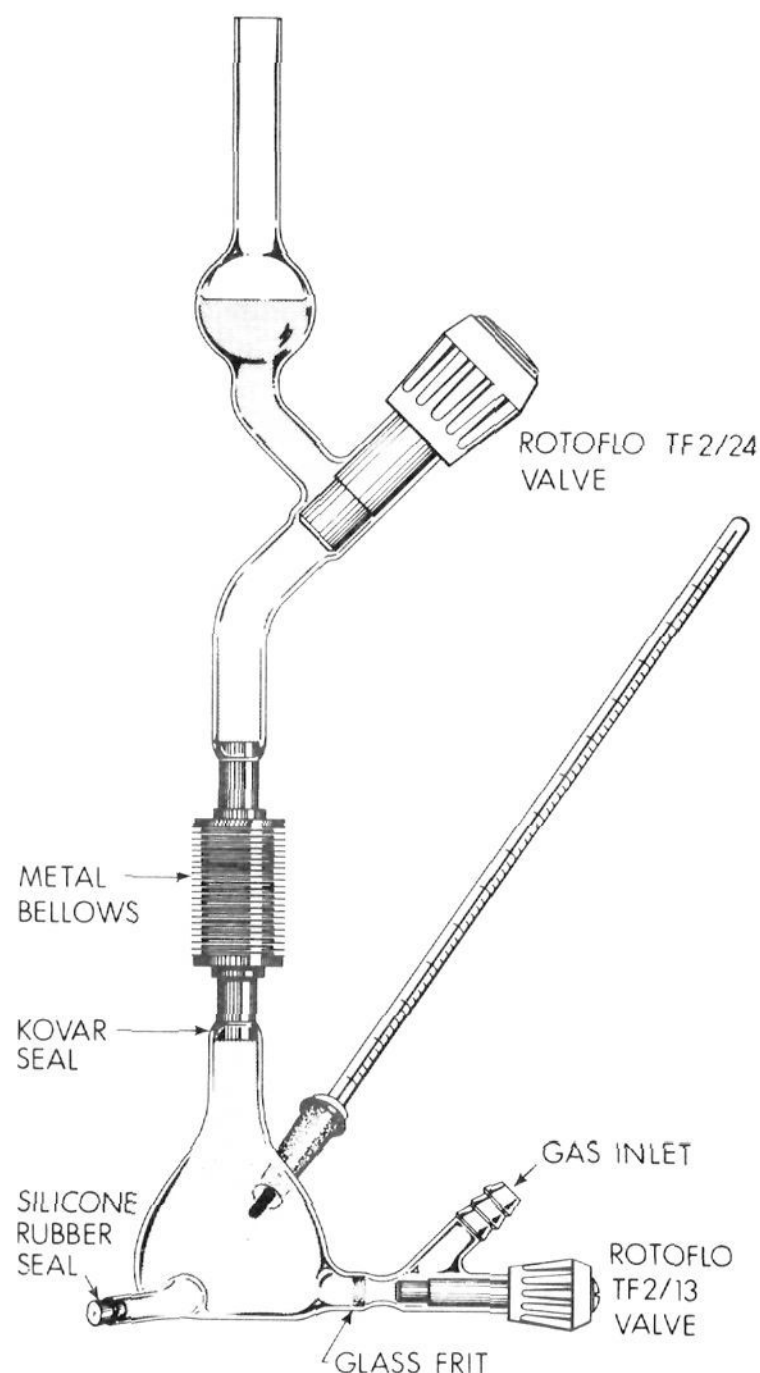

Figure 1. Apparatus for preparation of stock solution of gaseous solute. The total volume between the Rotoflo valves was about 100 cm³. The bellows was of stainless steel.

A solvent effect on the reaction rate of electrons in alcohols has been noted. It appears to reflect the relative magnitudes of the solvation energies in the alcohols.

Experimental Section

Materials. The method of purification of methanol was the same as that reported earlier,⁸ but the source material was different. Certified ACS Spectroanalyzed methanol from Fisher Scientific Co. and Commercial Grade methanol (5 ppm carbonyl, 20 ppm acid, and 70 ppm water) from Monsanto Co. ultimately gave longer half-lives for e^-_{soln} than did the Reagent Spectrophotometric Grade methanol from Baker Chemical Co. used previously. The first two sources were therefore used. Purification⁸ was done in a grease free Pyrex apparatus maintained at a slight positive pressure of flowing ultra high purity (UHP) argon which escaped through U-tubes containing mercury.

Absolute Reagent Grade ethanol from U.S. Industrial Chemical Co. was used as received.⁹ Contact with oxygen and moisture was avoided by fitting the ethanol bottle with a Pyrex syphon that was controlled by a Teflon stopcock. The bottle was maintained under about 100 Torr excess pressure of UHP argon.

Water was triply distilled.¹⁰

The UHP argon (Matheson Co.) was passed through a 1-m column of Oxisorb G (Messer Griesheim GMBH Industriegase).

Carbon dioxide (99.5%), acetylene (99.8%), and sulfur hexafluoride (99.8%) were obtained from Matheson Co. Oxygen (99.95%) was obtained from Alberta Oxygen Co. These gases were bubbled through two scrubbing columns containing triply distilled water then dried. Acetylene was passed through a trap held at 210 K by a chloroform slush bath, prior to the scrubbing columns.

Phillips Research Grade ethylene was used as received.

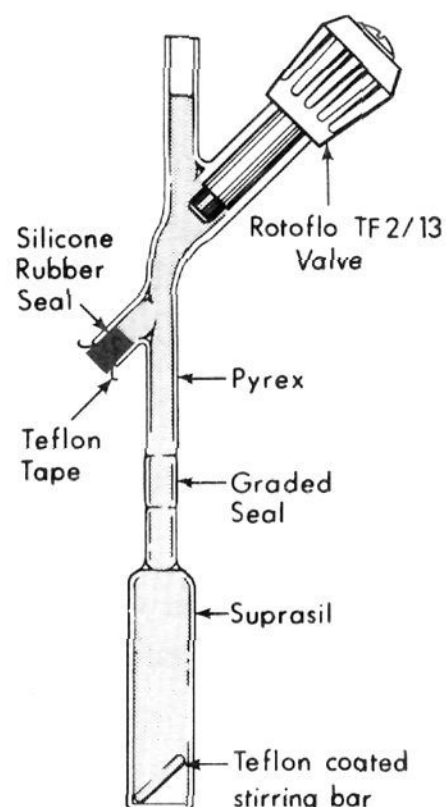

Figure 2. Suprasil optical cell fitted with a device for injection of aliquots of stock solution and subsequent mixing. Volume = 8 cm³. Optical path length = 1.00 cm.

The liquid and solid reagents were spectroquality or reagent grade. The organic compounds were distilled or sublimed before use.

Sample Preparation. The apparatus used for preparation of stock solutions saturated with a gaseous solute is shown in Figure 1. Gas entered the bubbler through a fine glass frit which produced small bubbles. The gas flow rate was 60 cm³/min. The solution was constantly stirred with a Teflon coated magnetic stirring bar. A thermometer fitted into the bulb through a grease free 10/30 ground glass joint.

To obtain an aliquot of the stock solution the needle of a microliter syringe (Hamilton Co.) was injected through the silicone rubber seal. The lower Rotoflo valve was closed and all gas bubbles were allowed to escape through the upper valve, which was then closed. Manual squeezing of the bellows (Metal Bellows Corp.) forced solution into the syringe, which was withdrawn before pressure on the bellows was released. The valves were then reopened and bubbling continued. This technique prevented solution degassing in the syringe. The solution concentration was checked regularly by gas chromatography (Hewlett-Packard 5750 Research Chromatograph, helium carrier gas, $\frac{3}{16}$ in. \times 6 ft column of 30/40 mesh silica gel, temperature programmed). The gas chromatograph was calibrated using 10 and 25 μ l gas tight syringes.

The irradiation cell (Figure 2) was filled to above the valve with pure solvent. It was deoxygenated by bubbling with argon at a flow rate of 40 cm³/min for at least 30 min through a stainless steel needle inserted through the top to the bottom of the cell. The needle was then withdrawn to just above the valve seat and the valve was closed. This left no gas volume in the sample. Only when injections of stock solution of >50 μ l were necessary was a small gas volume left in the cell to prevent breakage upon injection. The solvated electron lifetime was measured in the solvent before syringe addition of the solute solution.

Solute and solvent were thoroughly mixed with the Teflon coated bar (Figure 2) by repeatedly inverting the cell.

Several injections of an argon saturated solution into pure solvent in the cell did not decrease the half-life of solvated electrons. This demonstrated that the technique did not inadvertently introduce impurities into the system.

Ostwald Absorption Coefficients. Ostwald absorption coefficients L of the gases in water, methanol, and ethanol were calculated from the gas chromatographic results.

$$L = V_g/V_l \quad (1)$$

where V_g and V_l are respectively the volumes of gaseous solute and liquid solvent at the same temperature and pressure. Values of L are listed in Table I. The average disagreement with literature values is ~15%.

Table I. Ostwald Absorption Coefficients

Solvent	Solute	T, °K	L	
			Present	Lit.
H ₂ O	C ₂ H ₂	295	0.97	
	C ₂ H ₄	296	0.1	
	1,3-C ₄ H ₆	293	0.47	
	CO ₂	295	1.03	0.87 ^a
	N ₂ O	295	0.63	0.63 ^a
	O ₂	296		0.032 ^a
	SF ₆	296		0.0058 ^b
CH ₃ OH	C ₂ H ₂	295	13.1	
	C ₂ H ₄	296	2.4	
	CO ₂	295	4.9	3.5, ^a 4.2 ^a
	N ₂ O	296	3.8	3.23 ^a
	O ₂	296	0.22	0.25 ^c
	SF ₆	294	0.54	
	C ₂ H ₅ OH	C ₂ H ₂	295	7.6
C ₂ H ₄		296	2.6	
CO ₂		295		2.8 ^a
N ₂ O		296	3.3	2.9 ^a
O ₂		298		0.24 ^a
SF ₆		294	0.70	

^a W. F. Linke, "Solubilities. Inorganic and Metal-Organic Compounds", Vol. 1, 4th ed, American Chemical Society, Washington, D.C., 1958; Vol. 2, 1965. ^b H. L. Friedman, *J. Am. Chem. Soc.*, **76**, 3294 (1954). ^c C. B. Kretschmer, J. Nowakoska, and R. Wieve, *Ind. Eng. Chem.*, **38**, 506 (1946).

The concentration of solute S in a solution saturated at atmospheric pressure is

$$[S] = (LP \times 273)/(22.4 \times 760T) \quad (2)$$

where P is the atmospheric pressure in Torr and T is the absolute temperature of the solution. In all instances except SF₆ in water, the presently measured values of L were used to calculate the solute concentrations. The solubility of SF₆ in water is too small to measure by our technique, so the literature value was used (Table I).

The value of L was not measured for CO₂ or O₂ in ethanol. Only small amounts, <0.1 vol %, of stock solution were required to be added to the pure solvents. The same value of k_2 was obtained for SF₆ in ethanol whether the methanolic or ethanolic stock solution of SF₆ was injected. For convenience, the methanolic stock solutions of CO₂ and O₂ were used in both alcohols.

Irradiation and Measurement. The irradiation, dosimetry, and spectrophotometry were done essentially as described earlier.¹⁰ In brief, a 100 ns pulse of 1.7 MeV electrons delivered 3×10^{16} eV/g to the sample. The dosimeter was oxygen saturated 2 mM potassium thiocyanate, using $G((\text{SCN})_2^-) = 2.8$ and $\epsilon_{478} = 7500 \text{ M}^{-1} \text{ cm}^{-1}$.

A Pyrex filter was put into the Xe arc lamp housing to remove light with $\lambda < 320 \text{ nm}$. This prevented ozone formation in the room.

Results and Discussion

Solvated electrons in alcohols and water react by (3) and (4)

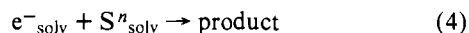
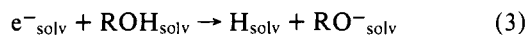

where n indicates the charge on the scavenger S ^{n} . Both reactions are pseudo first order because the concentrations of solvent ROH and solute S ^{n} are much greater than that of e⁻_{solv}. The first-order decay rate $k = (k_3[\text{ROH}] + k_4[\text{S}^n])$ in a given solvent was measured as a function of solute concentration [S ^{n}]. The value of k_4 was obtained from the slope of a plot of k against [S ^{n}].¹¹ Three to nine different concentrations were used in each case. The nature and quality of the results are shown in Figure 3.

Values of k_4 obtained for a number of gaseous solutes in water, methanol and ethanol are listed in Table II. Of the seven cases where comparison is possible with earlier work,^{4,6,12,13}

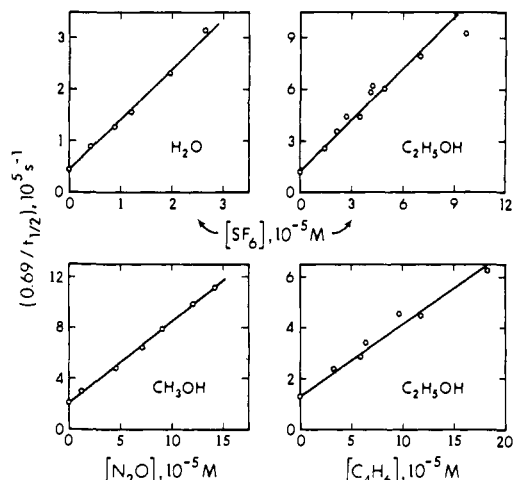

Figure 3. Plots of first order decay rates ($0.69/t_{1/2}$) of solvated electrons against solute concentration in water, methanol, and ethanol at $296 \pm 2 \text{ K}$.

Table II. k_4 for Gaseous Solutes in Different Solvents at $296 \pm 2 \text{ K}$

S	$k_4, 10^8 \text{ M}^{-1} \text{ s}^{-1}$		
	In H ₂ O	In CH ₃ OH	In C ₂ H ₅ OH
SF ₆	110 ± 10 (165 ± 10 ^a)	125 ± 10	100 ± 10
O ₂	(190 ± 20 ^b)	200 ± 10 (190 ± 30 ^c)	150 ± 10 (190 ± 40 ^c)
N ₂ O	79 ± 4 (71 ± 15 ^b)	63 ± 4 (130 ^d)	65 ± 7
CO ₂	73 ± 4 (77 ± 11 ^b)	72 ± 6	59 ± 7
1,3-C ₄ H ₆	32 ± 8 (80 ^b)	15 ± 1	28 ± 3
C ₂ H ₂	≤0.07	≤0.02	≤0.03
C ₂ H ₄	≤0.06	≤0.01	≤0.02

^a Reference 12. ^b Reference 4. ^c Reference 6. ^d Reference 13.

agreement exists in four of them within the experimental uncertainty (Table II). The other three earlier values were ~2 times larger than the present ones. Not enough detail was published in the earlier work to permit an evaluation of the differences. However, it has been pointed out³ that the earlier value for $k(e^-_{\text{solv}} + \text{N}_2\text{O})$ in methanol¹³ is probably too high by a factor of 2, in agreement with the present work.

The relative efficiencies of oxygen and sulfur hexafluoride for reaction with electrons in the liquid alcohols and water (Table II) are the reverse of those in the gas phase.¹⁴⁻¹⁶ In low density gases oxygen^{14,16} is a much less efficient scavenger of thermal electrons than is sulfur hexafluoride.¹⁵ The attachment of electrons to molecules may be represented by the mechanism¹⁷

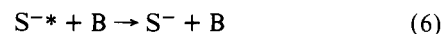

where B is any third body that removes energy from the excited ion S^{-*}, and P₁⁻ and P₂ are dissociation products of S^{-*}. The net rate constant for electron attachment is

$$k_{\text{at}} = k_5(k_6[\text{B}] + k_7)/(k_{-5} + k_6[\text{B}] + k_7) \quad (8)$$

In oxygen at atmospheric and lower pressures $k_{-5} \gg k_6[\text{B}]$, and for thermal electrons $k_6[\text{B}] \gg k_7$, so (8) reduces to (9).

$$k_{\text{at}} = k_5 k_6 [\text{B}] / k_{-5} \quad (9)$$

$$\ll k_5$$

When B is water¹⁴ or methanol¹⁶ vapor the value of k_{at} for oxygen is $4 \times 10^{12} \text{ M}^{-2} \text{ s}^{-1}$ at room temperature. In sulfur hexafluoride at all pressures measured, down to $\ll 1$ Torr, $k_{-5} \ll (k_6[\text{B}] + k_7)$ and (8) reduces to

$$k_{\text{at}} = k_5 \quad (10)$$

The value^{15,17} at room temperature is $k_{\text{at}} = 2 \times 10^{14} \text{ M}^{-1} \text{ s}^{-1}$, which is at least four orders of magnitude greater than that for oxygen in alcohol or water vapor at attainable densities.

For the liquid phase one can write

$$k_{\text{at}} = k_4 \quad (11)$$

The values in the liquid alcohols and water are $10^{10} \text{ M}^{-1} \text{ s}^{-1}$, four orders of magnitude lower than those one would obtain by extrapolation from the gas phase to a liquidlike density ($[\text{B}] \approx 25 \text{ M}$ in methanol, whence the extrapolated rate constant for oxygen would be $1 \times 10^{14} \text{ M}^{-1} \text{ s}^{-1}$). The reason for the difference is that the solvated electron mobilities in these liquids, $\sim 10^{-3} \text{ cm}^2/\text{V s}$,¹⁸ are four orders of magnitude lower than one would expect for a gaslike electron mobility in a fluid of that density, $\sim 10 \text{ cm}^2/\text{V s}$.¹⁹ However, it is interesting that the rate constant for sulfur hexafluoride becomes smaller than that for oxygen in the liquid phase. Furthermore, in methanol the values of k_4 for oxygen and sulfur hexafluoride are smaller than that for the more slowly diffusing²⁰ nitrobenzene (Table III). This indicates that the oxygen and sulfur hexafluoride reactions are not diffusion controlled. The reaction between solvated electrons and sulfur hexafluoride has commonly been considered to be diffusion controlled, by extrapolation from the large attachment coefficient for thermal electrons in the gas phase. Solvation affects the attachment efficiency by altering the energetics of the reactions; ($e^- + \text{S}$) and S^- do not have the same solvation energies.

Solvent Effect on Electron Attachment Efficiency. Values of k_4 were measured for a number of solutes in methanol and ethanol to look for variation in $k_{4,\text{M}}/k_{4,\text{E}}$, the ratio of the rate constants for a given solute in methanol and ethanol, respectively. Solute were chosen to display a wide range of values of k_4 . The separate values are listed in Table III and $k_{4,\text{M}}/k_{4,\text{E}}$ is plotted against $\log k_{4,\text{M}}$ in Figure 4. The ratio $k_{4,\text{M}}/k_{4,\text{E}} \approx 0.18$ for $k_{4,\text{M}} \leq 10^7 \text{ M}^{-1} \text{ s}^{-1}$; it increases for larger rate constants, reaching $k_{4,\text{M}}/k_{4,\text{E}} = 1.7 \pm 0.1$ at the highest $k_{4,\text{M}}$ measured (Figure 4). The highest ratio obtained with a neutral solute was 1.5.

The ratios of the diffusion coefficients of simple molecules²¹ and salts²² in methanol and ethanol at 298 K are ~ 2.3 (Table IV). The ratios lie midway between that of η^{-1} , the reciprocal shear viscosities,²³ and that of τ^{-1} , the reciprocal rotational relaxation times²⁴ (Table IV). The mobility ratios for anions, and probably that for solvated electrons in alcohols,^{25,26} are close to that of η^{-1} , in approximate agreement with Walden's rule. The mobility ratios for cations are larger and are closer to that of τ^{-1} (Table IV), which indicates a major contribution of rotational polarization to the limiting of cation migration rates. It appears that for a diffusion controlled reaction between solvated electrons and a neutral scavenger one should find $k_{4,\text{M}}/k_{4,\text{E}} \geq 2.0$.²⁷ The fact that the highest ratio found for this type of reaction was 1.5 implies that all the present reactions are slower than diffusion controlled. Extrapolation of the curve in Figure 4 to $k_{4,\text{M}}/k_{4,\text{E}} \geq 2.0$ gives $k_{4,\text{M}} \geq 6 \times 10^{10} \text{ M}^{-1} \text{ s}^{-1}$ for reaction with a neutral solute.²⁸

In summary, $k_{4,\text{M}}/k_{4,\text{E}}$ varies from an apparent upper limit ≥ 2.0 to a lower limit of 0.18. The upper limit is due to the higher diffusion coefficients in methanol. The lower limit is attributed to the greater electron solvation energy in methanol,

Table III. Solvent Effect on k_4 at $296 \pm 2 \text{ K}$

S	$k_{4,\text{M}}$, $\text{M}^{-1} \text{ s}^{-1}$ ^a	$k_{4,\text{E}}$, $\text{M}^{-1} \text{ s}^{-1}$ ^a	$k_{4,\text{M}}/k_{4,\text{E}}$
Acid, perchloric	5.4×10^{10}	3.2×10^{10}	1.7 (2.2 ^b)
	6.5×10^{10} ^c	3.6×10^{10} ^c	1.8
	6.8×10^{10} ^d	4.5×10^{10} ^d	1.5
Neutral, diffusion controlled ^e	6×10^{10}	2.6×10^{10}	2.3
Nitrobenzene	2.3×10^{10}	1.5×10^{10}	1.5
Oxygen	2.0×10^{10}	1.5×10^{10}	1.3
Sulfur hexafluoride	1.3×10^{10}	1.0×10^{10}	1.3
Carbon dioxide	7.2×10^9	5.9×10^9	1.2
Nitrous oxide	6.3×10^9	6.5×10^9	0.97
Acetone	4.3×10^9	4.7×10^9	0.91
Naphthalene	3.0×10^9	4.3×10^9	0.70
1,3-Butadiene	1.5×10^9	2.8×10^9	0.54
Acetonitrile	8.6×10^7	3.2×10^8	0.27
Ethyl acetate	2.2×10^7	5.3×10^7	0.42
Phenol	7×10^6	5×10^7	0.14
Toluene	1.3×10^6	6.4×10^6	0.20
Benzene	1.2×10^6	6.4×10^6	0.19
<i>o</i> -Xylene	4×10^5	2.5×10^6	0.17
$E_{\lambda_{\text{max}}}$, kcal mol ⁻¹ ^f	45	41	$\Delta G_{\text{S,M}} - \Delta G_{\text{S,E}} \approx 4$

^a $k_{4,\text{M}}$ and $k_{4,\text{E}}$ represent k_4 in methanol and ethanol solvents, respectively. The experimental scatter for each rate constant was 5–10%.

^b Corrected for the effect of dielectric constant on the reactant interaction radii, to allow comparison with the ratio for neutral solutes: $1.7 \times 33/25 = 2.2$. ^c Reference 11. ^d Reference 25. ^e Estimate. ^f Energy of the optical absorption maximum of e^-_{solv} ; refs 2 and 3. The difference reflects the difference in solvation free energies; ref 29.

which makes electron transfer to inefficient solutes more endoergic in methanol than in ethanol.

The free energy of electron solvation is reflected by the energy of the optical absorption maximum of e^-_{solv} ,²⁹ which is 4 kcal/mol greater in methanol than in ethanol (Table III).

Electron capture in the liquid phase occurs by a mechanism similar to (5)–(7), but the solvent is intimately involved:

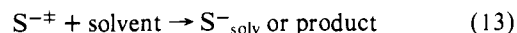

Solvent rearrangement can make important contributions to the free energy changes of both (12) and (13).³⁰ The products of (13) can include those of dissociation of $\text{S}^{-\ddagger}$, so it represents the liquid phase equivalent of both (6) and (7). Reaction 13 is first order.

For simplicity we will consider neutral scavengers S, although charged scavengers could be treated with little difficulty (for example, see ref 27). The overall capture rate constant k_4 is:

$$k_4 = k_{12}k_{13}/(k_{-12} + k_{13}) \quad (14)$$

A diffusion controlled reaction has $k_{-12} \ll k_{13}$, so (14) reduces to (15).

$$k_4 = k_{12} = k_{\text{dc}} = A_{\text{dc}} \exp(-E_{\text{dc}}/RT) \quad (15)$$

where $A_{\text{dc}} = 4\pi r D_0$, r is the reaction radius, D_0 is the preexponential factor for the mutual diffusion coefficient of the reactants, and E_{dc} is the Arrhenius temperature coefficient of mutual diffusion.

Slower reactions can be limited by either or both of (12), (12) and (13). The present work points to a correlation between the solvation energy of the electron and the value of k_4 for a given solute in the solvent, when $k_4 < k_{\text{dc}}$. In solvents

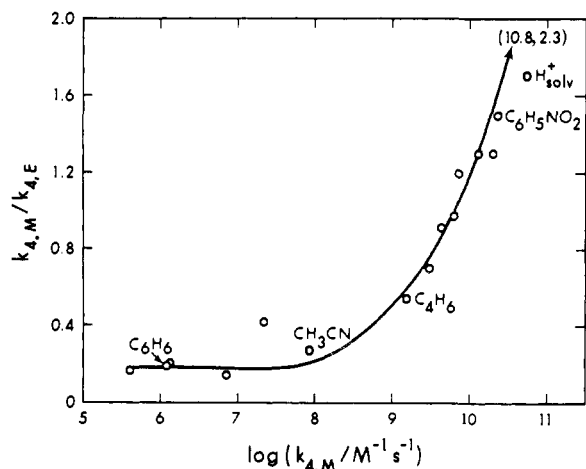

Figure 4. Variation of the ratio of k_4 in methanol and ethanol solvents, $k_{4,M}/k_{4,E}$, with the reactivity of the solute (represented by $k_{4,M}$). The full curve was calculated from eq 20 for neutral scavengers. The point for H^+_{solv} lies below the curve for neutral solutes because the different solvent dielectric constants inversely alter the ion–electron interaction distance. Temperature = 296 K.

where the electron solvation energy is greater, k_4 tends to be smaller.

Solvation processes (including desolvation) can contribute to the attainment of the activated state in (12) and to the stabilization through (13) of electron capture. Solvation changes involve rotational relaxation of the solvent about the reactant pair and concomitant translational relaxation due to changes in local electrostriction. The rate of these changes is related to that of dielectric relaxation modified by electrostatic torques exerted by the charged solute on the solvating dipoles.^{31–33} The local torques change when the charge center shifts in (12). The time required for the solvent rearrangement is expected to be an order of magnitude smaller than that for the largest and slowest component of relaxation, τ_1 , measured by microwave spectroscopy.^{31,34} The excess electron would also weaken hydrogen bonds in its vicinity. The minimum time required for the solvent rearrangement processes would be similar to the second component τ_2 measured by microwave spectroscopy.³⁴

When the rate is limited by (12) one has³⁵

$$k_4 \approx (kT/h) \exp(-\Delta G^\ddagger_4/RT) \quad (16)$$

with the free energy of activation ΔG^\ddagger_4 equal to that of (12). At 296 K the magnitude of kT/h is 6×10^{12} , which is convenient for the preexponential factor of k_4 in units of $M^{-1} s^{-1}$. For example, it gives the estimated diffusion controlled limit for neutral S in methanol, $6 \times 10^{10} M^{-1} s^{-1}$, with $\Delta G^\ddagger_4 = 2.8$ kcal/mol, which is equal to the activation energy of self diffusion in methanol.³⁶ Values of ΔG^\ddagger_4 were calculated for the neutral solutes in Table III and are denoted by $\Delta G^\ddagger_{4,M}$ for methanol and $\Delta G^\ddagger_{4,E}$ for ethanol solutions. A plot of $(\Delta G^\ddagger_{4,M} - \Delta G^\ddagger_{4,E})$ against $\Delta G^\ddagger_{4,M}$ is shown in Figure 5. For discussion purposes k_4 and ΔG^\ddagger_4 may be divided into two portions, one representing the diffusion together of the reactants, k_d and ΔG^\ddagger_d , and another representing reaction after the reactants have formed an encounter pair, k_r and ΔG^\ddagger_r , respectively.

$$k_4^{-1} = k_d^{-1} + k_r^{-1} \quad (17a)$$

$$\exp(\Delta G^\ddagger_4/RT) = \exp(\Delta G^\ddagger_d/RT) + \exp(\Delta G^\ddagger_r/RT) \quad (17b)$$

The minimum value of ΔG^\ddagger_4 is equal to ΔG^\ddagger_d , with $\Delta G^\ddagger_r = 0$. When $\Delta G^\ddagger_r < \Delta G^\ddagger_d$ one has $\Delta G^\ddagger_4 \approx \Delta G^\ddagger_d + \Delta G^\ddagger_r$, with the contribution of ΔG^\ddagger_d decreasing as ΔG^\ddagger_r increases. When $\Delta G^\ddagger_r \gg \Delta G^\ddagger_d$ one has $\Delta G^\ddagger_4 \approx \Delta G^\ddagger_r$.

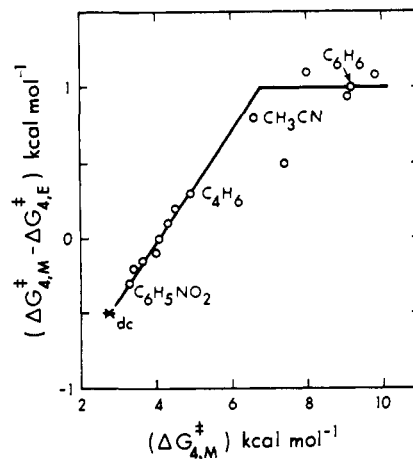

Figure 5. The difference between the free energies of activation of electron scavenging in methanol ($\Delta G^\ddagger_{4,M}$) and ethanol ($\Delta G^\ddagger_{4,E}$) plotted against $\Delta G^\ddagger_{4,M}$ for neutral scavengers. The free energies were calculated from (16). (O) Scavengers from Table III; (*) estimated diffusion controlled limit at 296 K. The full curve is equivalent to eq 18.

Table IV. Diffusion Coefficients and Ion Conductances in Alcohols at 298 K

	Methanol	Ethanol	Methanol/ ethanol
$D, (10^{-5} \text{cm}^2 \text{s}^{-1})^a$	2.3	1.0	2.3
$\Lambda_\infty, \text{cm}^2 \Omega^{-1} \text{mol}^{-1} b$			
$H^+ + RO^-$	195	83	2.4
$H^+ + Cl^-$	193	82	2.4
$Na^+ + Cl^-$	97	43	2.3
$\lambda_\infty, \text{cm}^2 \Omega^{-1} \text{mol}^{-1} b$			
H^+	142	57	2.5
Na^+	46	18	2.5
RO^-	53	25	2.1
Cl^-	51	24	2.1
$\eta^{-1}, \text{cP}^{-1} c$	1.79	0.90	2.0
$\tau^{-1}, \text{ns}^{-1} d$	21.3	7.8	2.7

^a Self diffusion coefficient; ref 21. ^b Equivalent conductance at infinite dilution; ref 22. Other uni-univalent salts have conductances similar to that of sodium chloride. The mobility $u(\text{cm}^2 \text{V}^{-1} \text{s}^{-1}) = 1.04 \times 10^{-5} \lambda_\infty$. ^c Reciprocal shear viscosity; ref 23. ^d Reciprocal dielectric (rotational) relaxation time; ref 24.

At the diffusion controlled limit $(\Delta G^\ddagger_{4,M} - \Delta G^\ddagger_{4,E})$ is negative because diffusion coefficients in methanol are greater than those in ethanol; $\Delta G^\ddagger_{d,M} \approx 2.8$ kcal mol⁻¹ and $\Delta G^\ddagger_{d,E} \approx 3.3$ kcal mol⁻¹ (Figure 5). As one proceeds to less reactive solutes the free energy of activation increases more rapidly in methanol than in ethanol because the electron has to escape from a 4 kcal mol⁻¹ deeper solvation trap in the former (Table III). This energy is partially compensated by interactions between the solvent and S^{\pm} , so the maximum difference between $\Delta G^\ddagger_{4,M}$ and $\Delta G^\ddagger_{4,E}$ is less than 4 kcal mol⁻¹. The curve in Figure 5 is equivalent to (18).

$$\Delta G^\ddagger_{4,E} = 0.62\Delta G^\ddagger_{4,M} + 1.6, \Delta G^\ddagger_{4,M} < 6.8 \text{ kcal mol}^{-1} \quad (18a)$$

$$\Delta G^\ddagger_{4,E} = \Delta G^\ddagger_{4,M} - 1.0, \Delta G^\ddagger_{4,M} > 6.8 \text{ kcal mol}^{-1} \quad (18b)$$

The product of (12) is stabilized by (13). If (12) were exoergic ΔG^\ddagger_r should be approximately zero and the reaction should be diffusion controlled. Collisional stabilization of S^{\pm} could occur within the duration of an encounter, which is ≥ 1 ps. None of the present reactions is diffusion controlled.

When (12) is only slightly endoergic, (13) may be simply the relaxation of the polar solvent about the new charge center S^- , thereby deepening the potential well and stabilizing the anion. This appears to be the case for solutes such as biphenyl and terphenyl, whose anions have been observed optically in alcohols.³⁷ Naphthalene probably behaves similarly, because its electron capture rate constant lies between those for biphenyl and terphenyl.³⁷ This category of reactions may be described as simple electron capture and pertains to solutes down to and including, 1,3-butadiene in Table III.

For reactions with larger values of ΔG^\ddagger_4 the electron capture may be stabilized by protonation of the anion by the solvent. In these cases the anion is so unstable that its steady state concentration remains below the detection limit in methanol and ethanol. However, there is a correlation between the value of k_4 and the volume of activation ΔV^\ddagger_4 for acetonitrile, ethyl acetate, toluene, and benzene; ΔV^\ddagger_4 increases with k_4 .³⁸ The correlation does not extend to the more efficient scavengers. The mechanism used to interpret the correlation was (12')-(13').³⁸

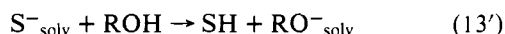
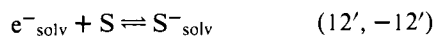

It would not be possible to completely resolve (13) and (13') for the less efficient scavengers, so (14) adequately describes the net electron capture rate constant.

When $k_{-12} \gg k_{13}$, (14) reduces to (19).

$$k_4 \approx k_{12}k_{13}/k_{-12} = k_{13} \exp(-\Delta G^\circ_{12}/RT) \\ = (kT/h) \exp[-(\Delta G^\ddagger_{13} + \Delta G^\circ_{12})/RT] \quad (19)$$

The free energy changes described by (17) and (18) apply to the entire range of k_4 , from (16) to (19). Equation 18b implies that at the larger values of ΔG^\ddagger_4 the difference between the solvent energies in the configurations associated with ($e^-_{\text{solv}} + S$) and S^- , and the ratio of the protonation rates of the anions by the solvents, are dependent upon the solvents but are relatively independent of S in the present series.

Equations 16-18 may be combined to give (20)

$$k_{4,M}/k_{4,E} = \exp([1.6 - 0.38\Delta G^\ddagger_{4,M}]/0.59) \quad (20a) \\ \Delta G^\ddagger_{4,M} < 6.8 \text{ kcal mol}^{-1}$$

$$k_{4,M}/k_{4,E} = 0.18, \quad \Delta G^\ddagger_{4,M} > 6.8 \text{ kcal mol}^{-1} \quad (20b)$$

where $0.59 \text{ kcal mol}^{-1} = RT$ at 296 K. The solid curve in Figure 4 represents this equation. The energy distribution function used for each system in these calculations was the delta function. Use of a more realistic (Gaussian) distribution function would soften the shoulder of the curve in Figure 5 and slightly raise the curve in Figure 4 in the region of $\log k_{4,M} = 7-8$.

A preliminary survey shows that the same type of behavior occurs in aqueous solution. The methanol water ratio $k_{4,M}/k_{4,W}$ for neutral solutes has an upper limit near unity. This will be the subject of a future investigation.

Reaction of e^-_{solv} with Unsaturated Hydrocarbons. Acetylene and 1,3-butadiene both react with sodium-potassium alloy, while ethylene does not. By contrast, 1,3-butadiene has a large rate constant for reaction with solvated electrons in alcohols and water, while acetylene and ethylene do not (Table II). This supports the conclusion that acetylene and butadiene

react with electrons by different mechanisms (see Introduction).

References and Notes

- (1) Supported by the National Research Council of Canada.
- (2) G. R. Freeman, *Natl. Stand. Ref. Data Ser., Natl. Bur. Stand., No. 48* (1974).
- (3) J. H. Baxendale and P. Wardman, *Natl. Stand. Ref. Data Ser., Natl. Bur. Stand., No. 54* (1975).
- (4) M. Anbar, M. Bambenek, and A. B. Ross, *Natl. Stand. Ref. Data Ser., Natl. Bur. Stand., No. 43* (1973).
- (5) G. R. Freeman and E. D. Stover, *Can. J. Chem.*, **46**, 3235 (1968).
- (6) I. A. Taub, M. C. Sauer, Jr., and L. M. Dorfman, *Discuss. Faraday Soc.*, **36**, 206 (1963).
- (7) J. D. Roberts and M. C. Caserio, "Basic Principles of Organic Chemistry", W. A. Benjamin, New York, N.Y., 1964, p 221.
- (8) K. N. Jha and G. R. Freeman, *J. Am. Chem. Soc.*, **95**, 5891 (1973).
- (9) S. M. S. Akhtar and G. R. Freeman, *J. Phys. Chem.*, **75**, 2756 (1971).
- (10) K. N. Jha, G. L. Bolton, and G. R. Freeman, *J. Phys. Chem.*, **76**, 3876 (1972).
- (11) K. N. Jha, G. L. Bolton, and G. R. Freeman, *Can. J. Chem.*, **50**, 3073 (1972).
- (12) K. D. Asmus and J. H. Fendler, *J. Phys. Chem.*, **72**, 4285 (1968).
- (13) H. Seki and M. Imamura, *Bull. Chem. Soc. Jpn.*, **44**, 1538 (1971).
- (14) J. L. Pack and A. V. Phelps, *J. Chem. Phys.*, **45**, 4316 (1966).
- (15) B. H. Mahan and C. E. Young, *J. Chem. Phys.*, **44**, 2192 (1966).
- (16) L. Bouty and H. Abgrall, "Proceedings of the International Conference on Physics of Atomic and Electronic Collisions", Publishing House Nauka, Leningrad, 1967, p 584.
- (17) G. R. Freeman, *Radiat. Res. Rev.*, **1**, 1 (1968).
- (18) J.-P. Dodelet, K. Shinsaka, and G. R. Freeman, *J. Chem. Phys.*, **59**, 1293 (1973).
- (19) T. Kimura and G. R. Freeman, 1974 Annual Report, Conference on Electrical Insulation and Dielectric Phenomena, National Academy of Sciences, Washington, D.C., 1975, pp 33-40.
- (20) Relative diffusion coefficients of neutral molecules vary approximately as the molar volume $V^{0.6}$: P. Chang and C. R. Wilke, *J. Phys. Chem.*, **59**, 592 (1955). The liquid molar volumes (cm^3/mol) are approximately 28 for oxygen, 80 for sulfur hexafluoride, and 100 for nitrobenzene: R. C. Weast, "Handbook of Chemistry and Physics", 50th ed, Chemical Rubber Publishing Co., Cleveland, Ohio, 1969.
- (21) D. W. McCall, D. C. Douglass, and E. W. Anderson, *J. Chem. Phys.*, **31**, 1555 (1959).
- (22) B. E. Conway, "Electrochemical Data", Elsevier, London, 1952, Chapter 4.
- (23) R. W. Gallant, "Physical Properties of Hydrocarbons", Vol. 1, Gulf Publishing Co., Houston, Texas, 1968; Vol. 2, 1970.
- (24) Calculated from data in F. Buckley and A. A. Maryott, *Natl. Bur. Stand. (U.S.), Circ., No. 589* (1958).
- (25) P. Fowles, *Trans. Faraday Soc.*, **67**, 428 (1971).
- (26) R. A. Vermeer and G. R. Freeman, *Can. J. Chem.*, **52**, 1181 (1974).
- (27) For reaction with a charged scavenger the ratio is affected by the change in dielectric constant ϵ of the solvent. A diffusion controlled reaction between oppositely charged univalent ions has a rate constant $k_{ac} = 1.12 \times 10^{10} \Delta/\epsilon \text{ M}^{-1} \text{ s}^{-1}$. For the diffusion controlled reaction between H^+_{solv} and RO^-_{solv} one predicts $k_M/k_E = (195 \times 24.3/82 \times 32.7) = 1.77$, in agreement with observation.²⁵ The same ratio is obtained for $H^+_{\text{solv}} + e^-_{\text{solv}}$ (Table III), which indicates that the encounter efficiency for this reaction is the same in both alcohols and may be similar to that in water, 0.3 (ref 11 and 25).
- (28) An implication is that, if the reaction radii were 10 Å the electron diffusion coefficients in methanol and ethanol would be about 5×10^{-5} and $2 \times 10^{-5} \text{ cm}^2/\text{s}$, respectively. These values are about triple those (1.5×10^{-5} and $8 \times 10^{-6} \text{ cm}^2/\text{s}$) obtainable from the data in ref 25. If the electron diffusion coefficients derived from ref 25 are correct our results imply a regular increase in reaction radius, with a correlation between those in methanol and ethanol. The large radii would involve tunneling. The solvent effects discussed in the present work are required to interpret the results, independent of whether the larger rates are attributed to larger diffusion coefficients of e^-_{solv} or to larger reaction radii.
- (29) J. Jortner and R. M. Noyes, *J. Phys. Chem.*, **70**, 770 (1966).
- (30) R. A. Marcus, *J. Chem. Phys.*, **24**, 966 (1956), and references therein.
- (31) G. R. Freeman, *Adv. Chem. Ser., No. 82*, 339 (1968).
- (32) K. N. Jha and G. R. Freeman, *J. Chem. Phys.*, **48**, 5480 (1968).
- (33) K. N. Jha and G. R. Freeman, *J. Chem. Phys.*, **51**, 2839, 2846 (1969).
- (34) S. K. Garg and C. P. Smyth, *J. Phys. Chem.*, **69**, 1294 (1965).
- (35) A. A. Frost and R. G. Pearson, "Kinetics and Mechanism", 2d ed, Wiley, New York, N.Y., 1961, Chapter 5.
- (36) J. R. Partington, R. F. Hudson, and K. W. Bagnall, *J. Chim. Phys.*, **55**, 77 (1958).
- (37) L. M. Dorfman and M. S. Matheson, *Prog. React. Kinet.*, **3**, 237 (1965).
- (38) G. L. Bolton, M. G. Robinson, and G. R. Freeman, *Can. J. Chem.*, **54**, 1177 (1976).